

# EnViron: An Integrated VR Tool for Engineering Projects

Ismael H. F. dos Santos<sup>1</sup>, Alberto Raposo<sup>2</sup>, Luciano P. Soares<sup>2</sup>, Eduardo T. L. Corseuil<sup>2</sup>,  
Gustavo N. Wagner<sup>2</sup>, Paulo I. N. Santos<sup>2</sup>, Rodrigo de Toledo<sup>2</sup>, Marcelo Gattass<sup>2</sup>

<sup>1</sup>Petrobras Research Centre - CENPES, Rio de Janeiro, Brazil

ismaelh@petrobras.com.br

<sup>2</sup>Tecgraf – Computer Graphics Technology Group / Department of Computer Science

PUC-Rio – Pontifical Catholic University of Rio de Janeiro, Brazil

{abraposo,lpsoares,thadeu,gustavow,psantos,rtoledo,mgattass}@tecgraf.puc-rio.br

## Abstract

One of the main objectives in engineering departments of large industries is the implementation of integrated information systems to manage their projects' life cycle. EnViron (ENvironment for VIRtual Objects Navigation) is an application motivated by the demand to use Virtual Reality (VR) in large industrial engineering models generated by CAD tools. EnViron's main goal is to offer 3D visualization resources for CAD models with enough realism to be used for virtual prototyping, collaborative design review, change management systems and training, among other activities.

**Keywords:** Virtual Reality, CAD models, Collaborative Virtual Prototyping and Design review,.

## 1. Introduction

Nowadays, the majority of industrial engineering projects are using 3D geometric models created by CAD systems due to the economical benefits and management capabilities that such models can provide. Modern CAD systems are evolving from drawing programs to collaborative design tools, associating geometric modelers with different tools, such as an Engineering Document Management System, Physical Plant Documentation, among others. This combination reflects the necessity to create the so called Plant Information Management (PIM), a data warehouse to reduce costs and enhance efficiency through improvements in the overall project life cycle control [1].

The applicability of VR techniques for 3D geometric CAD models has been restricted to design review, virtual prototyping and marketing purposes, mainly in the automotive and aircraft industries. More recently, 3D CAD models are starting to show their potential in VR applications for diverse purposes, such as ergonomic studies [2], safety training for Health, Safety Environments [3], and visualization of physical simulations, project documentation and real-time operational data.

In the present work, we are interested in the kind of VR-CAD integration that approaches VR as an advanced form of viewing CAD models in real time and interacting with them in common CAD model usages,

such as design review and training [4]. Additionally we are visualizing advanced engineering simulations (e.g. computational fluid dynamics, flowlines and riser analysis, etc.) in virtual environments (Figure 1).

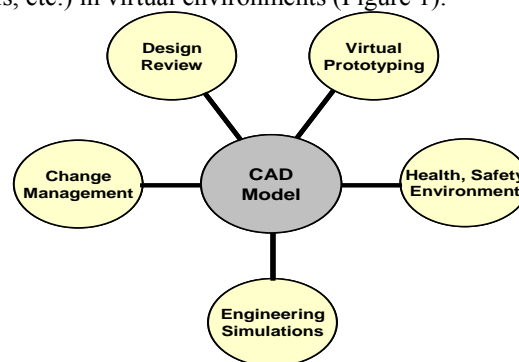

Figure 1 – CAD model as a centralized entity for integration of different applications.

However, in order to take advantage of VR in CAD systems, there are many challenges to overcome. One of them is related to the complexity of CAD models that were not intended to be viewed in real time. The achieved frame rates are unsatisfactory when very complex CAD models are loaded, especially in regions with large object concentrations. This is worsened by the fact that the CAD-to-VR conversion normally generates undesired model complexity.

Another challenge is photorealistic rendering. CAD models generally do not have material and texture attributes associated to objects, and although many CAD systems offer this possibility, design engineers usually do not use this resource. This happens because this information is not essential to the building process, which is the aim of CAD models. However, this information is important for a realistic VR visualization in the aforementioned applications.

EnViron is part of a research initiative to develop, in conjunction with CAD systems, an integrated information system to control engineering projects, offering resources for real-time 3D visualization and interaction in CAD models with enough realism and performance to be used for collaborative virtual prototyping, design review, change management systems, training, and engineering simulations among other activities.

The following section presents a brief overview of

the use of VR with CAD models. Section 3 discusses the main algorithms and techniques applied in EnViron, which is presented in section 4. Conclusions and future work follow in section 5.

## 2. CAD Models and VR

Several CAD tools are available, with very distinct characteristics. Some of them can deal with large amounts of data but lack integration with VR resources, such as different display and interaction devices. Other tools support several projection environments but have difficulties in rendering complex models. The fact is that there is not yet a fully-functional integrated system where one can migrate from a CAD to a VR model (and possibly vice-versa), allowing easy interaction to make the necessary adjustments. Actually, the process of using CAD models in VR applications is composed of a chain of (usually manual) adaptation steps [4], [5].

GigaWalk [6] and REVIEW [7] are academic solutions for real-time visualization of very large models. They use techniques such as hierarchical LOD and occlusion culling to achieve good performance. Commercial systems tend to have more generic objectives, and in general provide more resources for the VR visualization of CAD models, like Division Reality [8] and Walkinside [9]. However, they are restricted to a couple of CAD formats.

There are many CAD file formats available and some of them are not only badly documented but also proprietary. Conversion to a format adequate for VR visualization is not easy and often generates undesirable artifacts. A possible way to analyze the integration solutions is regarding the coupling between the CAD and VR software [10]. Through this analysis, we may distinguish four approaches:

1. Systems connected by means of gateways to ease the conversion process from the CAD to the VR model. This is the most common approach, suitable for the majority of CAD and VR systems. In this process, CAD models are converted to a format suitable for VR, such as X3D. Normally this format is exported by the CAD system. The drawback is that this approach does not offer any solution to common problems in the CAD-to-VR conversion, such as inadequate treatment of geometry, loss of semantics, etc.
2. Definition of a common file format for both CAD and VR models. An example of such approach is XMpLant, a "neutral" CAD format based on XML to describe process plants [11]. However, XMpLant is more focused on CAD-to-CAD formats conversion. In the CAD-VR integration context, XMpLant's interoperability potential is clearly useful, but VR tools that will use it as input still need to process it in order to solve some of the mentioned problems of CAD-to-VR conversion.

3. Systems connected by means of an API. An example is the use of OMG CAD Services interface [12], which is a CORBA-based interface standard to enable the interoperability of CAD, CAM (Computer Aided Manufacturing) and CAE (Computer Aided Engineering) tools. The current limitation of CAD services interface is that it has not been widely adopted by CAD and VR systems, demanding high implementation costs on both sides to integrate the CAD and the VR system with that interface.
4. Integration in one process, where the VR system is integrated into the core of the CAD system [4]. This approach is certainly the most capable of solving the problems related to CAD-VR integration, since the VR system can cover all of the CAD model's functions. However, it is a vendor-specific solution, lacking interoperability aspects present in the previous approaches.

EnViron adopts a hybrid approach between categories 1 and 3 above. At the end, the information extracted from the CAD system is stored in a file format developed for this system, similar to category 1 above. However, it is not simply a format exported from the CAD file. The format has been defined to include relevant semantic information, such as the links with associated databases. Moreover, the information is extracted from the CAD system by means of APIs native to the CAD systems, which enables the extraction of the relevant semantic information, similar to category 3.

EnViron is a system composed of a 3D environment for real-time model visualization, and exportation plug-ins, which translate model data from other applications to EnViron's internal format, a VR optimized file format called Tecdgn [13]. Some of the optimization techniques applied consist of smartly grouping object parts, based on a spatial data structure, to reduce the scene graph tree. Some of the optimizations used in EnViron will be further described in the following sections.

Currently we have developed two export plug-ins: for 3ds Max [14] and for MicroStation [15], the CAD tool used in PDS (Plant Design System) [1]. The goal of the MicroStation plug-in is not only to convert DGN files into a graphic format that enables real-time interaction and navigation in the CAD model, but also to recover and export the semantic information associated to CAD objects. In parallel, the 3ds Max plug-in enables the use of more photo-realistic models, not necessarily generated by a CAD tool.

## 3. Rendering Performance Optimizations

The CAD model can include detailed objects that increase the number of graphical primitives (polygons and textures, for instance). It is very common that either the amount of data is bigger than the memory capacity of the graphics card or the algorithm to synthesize the image is highly complex, requiring the application of tech-

niques that simplify the rendering in order to allow interactive visualization. In the following sections we describe some of the main optimization algorithms developed for EnViron.

### 3.1. Culling

A common acceleration technique is frustum culling. However, it only discards objects that are completely outside the viewing range, which clearly cannot guarantee good performance. On the other hand occlusion culling can speed up scenes where a significant amount of objects are hidden behind others. For engineering CAD models, such as power plants, oil platforms and refineries, the identification of occluders and occludees is a tough problem, especially when the user is flying over the whole model where no object can be discarded by a frustum culling technique.

Modern graphics cards allow the identification of objects hidden behind others by an occlusion query primitive. This way, we can avoid sending hidden objects to the GPU since they will not contribute to the final image. Before rendering a complex geometry, we test its bounding volume, disabling shading and updates on the frame buffer. Graphics cards allow querying the number of pixels that would be generated by the bounding volume tested. If this number is below a certain threshold (usually a small number, depending on the image resolution and the distance of the observer), we assume that the bounding volume cannot be seen and therefore its corresponding geometry is occluded. The algorithm known as Coherent Hierarchical Culling [16] uses this approach with several optimizations.

Since the result of an occlusion query takes some time to become available, there is a need to maintain the CPU and GPU busy, avoiding stalls and starvation problems. One major challenge is handling the issuing of queries asynchronously while traversing the hierarchy and rendering geometries that are found to be visible. This technique can be used successfully as an additional way to improve performance in 3D visualization.

Using the Coherent Hierarchical Culling algorithm, we have verified a significant increase in rendering performance with CAD models. Performance was measured as the time taken for an automatic camera to travel through the scene, varying the number of visible and occluded objects for each point of view. A reference time was taken without using any acceleration algorithm. In a test scene of a real oil platform, with 91K objects and 4.7M vertices, we measured a performance at least 2 times faster with the culling algorithm than the reference time. In some situations, depending on the current point of view, performance was 5 times faster. This guaranteed interactive frame rates in the application, which in turn allows for better scene interaction and immersion experiences.

### 3.2. Far Voxels

To render massive models, EnViron uses an algorithm based on the Far Voxels technique [17]. This algorithm uses hierarchical level-of-detail (HLOD) structures where intermediate (coarse) representations of submodels are represented by voxels. This HLOD with voxel representation yields interactive frame rates for large data sets because it deals well with levels of detail, culling, occlusion and out-of-core model storage.

The Far Voxels algorithm, however, has a severe drawback when dealing with very detailed CAD models. These models have a large quantity of lines and thin objects that, even when represented in full detail, introduce very high spatial frequencies that cannot be rendered without proper anti-aliasing treatment. Aliasing is especially noticed during model navigation, where these thin objects create disturbing popping effects between consecutive frames.

In the original Far Voxels algorithm the temporal aliasing problem is aggravated when thin objects are converted into voxels. The voxels used to represent these objects tend to create representations which are larger than the ones of the original geometric representation, as in Figure 2. In addition to creating a representation that is very different from the original model, this distortion causes very noticeable popping artifacts in the transition between different levels of detail.

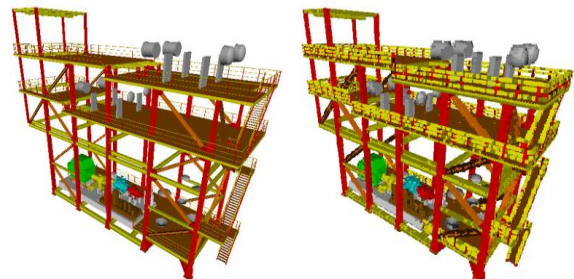

**Figure 2 - Thin objects: (left) as geometry, (right) represented as voxels, causing visual artifacts.**

We have implemented a method to detect this type of voxel and an alternative voxel representation, as explained in [18]. This method uses transparency to achieve an image quality that is closer to the one obtained with current 3D hardware anti-aliasing using the fully detailed representation of the model (using triangles and lines).

### 3.3. Specialized CAD GPU primitives

Modern GPUs provide great flexibility to vertex and pixel processing, allowing the creation of new applications with powerful graphical effects. One promising research area is the creation of new GPU primitives (spheres, cylinders, cones and tori) to extend the default ones (triangles, lines and points). The benefits of these

new primitives compared to their tessellated counterparts (usually represented by triangle meshes) are: better image quality with precise silhouette and per-pixel depth/shading, less memory usage and improved rendering efficiency.

In our implementation, GPU primitives are visualized through a ray-casting algorithm implemented inside the graphics card with vertex and fragment shaders [19]. This technique furnishes a parametric description for each engineering object, which allows putting them in Display Lists and grouping parametric objects of similar types in clusters. Grouping small geometries in clusters is a key factor to improve rendering performance on large scenes, once we avoid excessive vertex and fragment shaders reloading. Additionally, the amount of processing resources required by the fragment shader for each object is proportional to the number of fragments rendered, which is proportional to the space occupied by the object on the screen. This creates a kind of "intrinsic LOD", reducing the computational cost of rendering small objects.

### 3.4. Reverse Engineering

Usually engineering objects such as valves, pipes and pipe joints, used in CAD models, are represented by implicit surfaces in the modeler (Figure 3). Due to the huge number of engineering objects normally present in industrial plants such as oil refineries and platforms, the exportation of CAD models for visualization yields very large models. We have verified that for a medium-sized oil platform with 50 million polygons about 80% of the meshes are usually derived from the tessellation of engineering objects [19].

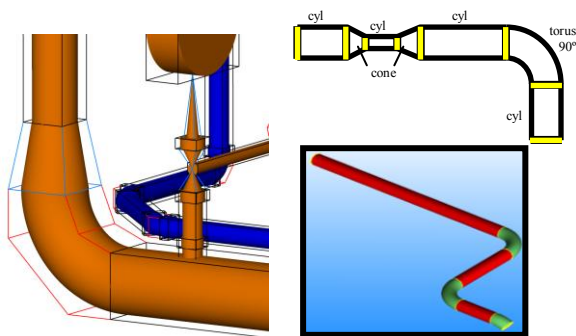

**Figure 3 – An oil platform and a flow pipeline rendered with GPU primitives.**

Once the usage of our extended GPU primitives represents a valuable performance improvement and better rendering quality for the models, it turns out that identifying those primitives in object meshes is a key issue that would lead us to even better performance results. This process of replacing a collection of GPU primitives with their equivalent complex triangulated meshes is called reverse engineering. The reverse-

engineering algorithm recovers the primitives from triangle meshes after discovering segment tubes composed of cylinders, truncated cones or torus slices. The identification of the segments starts by traversing the mesh trying to detect the presence of circular regular sections (rings) and estimating their properties. By verifying consecutive rings it is possible to determine whether they correspond to a cylinder, a cone section or an elbow, thus allowing us to replace the triangulated geometry by its equivalent collection of GPU primitives.

## 4. Application Scenarios

EnViron is a VR system capable of providing real-time 3D visualization and interaction with complex CAD models. In the following sections the application's main features are explored.

### 4.1. Design Review

Design review is the process of checking the correctness and consistency of an engineering project, and making the necessary corrections to it. VR techniques may be very helpful in this process, for instance to assess the safeness of different emergency escape pathways in case of an emergency in the plant. As the number of details increases, the software must be capable of visualizing and interacting with these models in real time. In order to achieve interactive frame rates, culling and Far Voxels techniques are applied.

Object manipulation is an important resource in design review. The ability of moving, rotating and scaling objects is important for various purposes such as joining different models in a scene, viewing hidden portions of the model, planning the placement of a new piece of equipment on a plant, and simulating a maintenance or intervention operation. The measurement of accurate distances between different objects in the CAD model is also an important feature. In Figure 4 a user is moving the object to test if a small shift will help an ergonomic maintenance task.

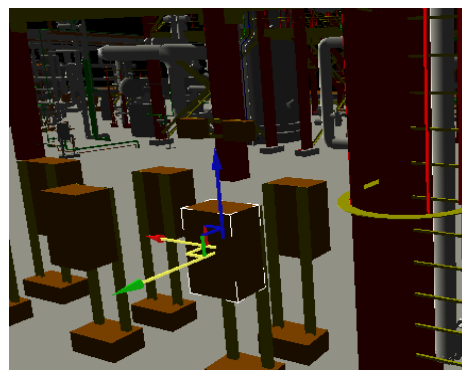

**Figure 4 – Manipulating objects.**



Tracking is a natural way to interact in large display environments, such as those present in 3D visualization rooms where design review teams generally work.

Another important aspect in design review is the integration of the visualized model with project information. Several CAD models have technical information attached to each object. Using database resources it is possible to recover this information in real time and use it to help the user taking operational decisions. Figure 5 shows a simple menu with information on a gas tank. It is possible to know what kind of gas it holds and if that place is a good option to build the structure. Moreover, integration with a database is useful to allow the user to create annotations on the model emphasizing critical parts. It is also possible to show comments attached to objects, which can be used, for example, as recommendations for project management.

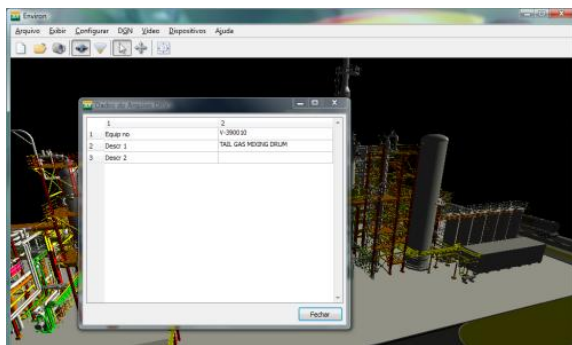

Figure 5 – Engineering information.

## 4.2. Engineering Simulations

During the conceptual design phase of an industrial plant, several simulations should be applied to assess the robustness and feasibility of the project. Some of these simulations may require huge computational efforts to be processed, even for powerful computer clusters. Visualization should be as precise as possible in order to provide the user a full understanding of the results of the simulation. EnViron is being developed with the goal of visualizing some of those simulations, such as riser analysis and CFD computations.

Oil platforms use ascending pipes, called risers, to bring the oil from the wellhead on the sea floor to the oil platform's separator system tanks. The risers are connected to the platform using special connections called “joints”. To validate the operation of the risers during their life cycle (around 20 years or so), simulations of the stress applied to the riser system are conducted based on meteo-oceanographic information about wind, tide and water currents. In order to avoid operational problems, simulations are made under extreme wave conditions to test stress resistance. One of the riser analysis software used is Anflex [20], an internally developed Finite-Element-based structural analysis package which is quite precise but has a poor built-in graphical representation. EnViron uses sophisticated graphical

techniques to present these simulations in an immersive virtual environment. Since risers can be represented, in a simplified way, as a sequence of annular cylinders, GPU primitives are used to render the whole stream, enabling users to have a close view of the pipes without losing resolution (Figure 6).

Among other resources, it is possible to playback the simulation, examine pipes, sea waves and ship movements, and track elements in the risers that are subjected to extreme conditions (e.g., high stress values). It is also possible to select any element in a riser and examine it closely, especially those elements in places subjected to great stress.

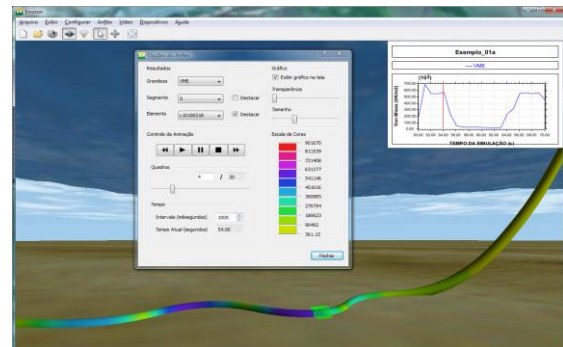

Figure 6 – Riser visualization.

Another important simulation visualized by EnViron is based on Computational Fluid Dynamics (CFD). Particles are used to show the flow movement, with additional information included in color. Figure 7 presents the air flow over an oil platform, where particle colors represent the speed of each particle. Using this kind of simulation, it is possible to analyze smoke dispersion in case of accidents, for instance.

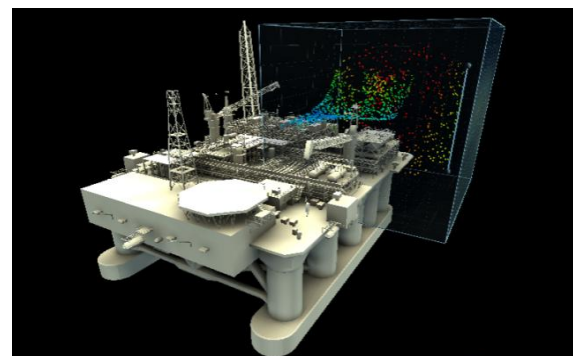

Figure 7 – CFD visualization.

## 4.3. Special Effects

Natural environments are special effects that give realism to the scene. Sky, ocean, shadows and terrain are examples used in EnViron.

EnViron allows real world terrain data to be imported. These data are usually represented as height fields stored in a CAD file. They can be easily converted to a 3D mesh, which can be used in our real-time

3D visualization. As the information present in this data is geo-referenced, it can be merged with existing aerial or satellite photos, as long as these are also geo-referenced. These photos can be painted over the existing terrain mesh to allow the identification of real characteristics of the region in the visual simulation. Existing CAD models can be inserted at their correct positions on the terrain mesh, allowing users to make advanced analysis involving terrain and CAD models.

Since oil platforms are not on the ground, but in the sea, it is important to simulate the sea and its natural behavior. In order to increase realism, GPU programmable shader effects are applied, showing better water highlights and bumps (Figure 8).



Figure 8 – Sea simulation.

## 5. Conclusions and Future Work

EnViron is part of a research initiative to create an infrastructure for the “immediate” generation of VR environments from CAD models, a task that currently requires significant effort from VR teams in the industry. In this context, EnViron has been designed to be an extensible tool, with flexibility to receive new functionalities and to incorporate plug-ins, according to different requirements of the industry. This concept is the opposite of that available in commercial solutions, normally offered as “black boxes”, with enhancements implemented by the developer on demand. We have successfully overcome CAD-to-VR conversion problems, being able to include visual effects while ensuring the interactive visualization of complex models.

Due to the increasing amount of multi-projection environments, support for computer clusters and multi-viewpoint rendering for collocated collaboration are some of our priorities for EnViron’s development.

## Acknowledgments

The authors would like to thank Petrobras and Tecgraf/PUC-Rio for their expressive support. Tecgraf is a laboratory mainly funded by PETROBRAS.

## References

[1] Intergraph, 2007. SmartPlant Enterprise, Plant and Ship Design and Engineering. <http://www.intergraph.com/>

[2] Monacelli, G., Sessa, F. and Milite, A. An Integrated Approach to Evaluate Engineering Simulations and Ergonomics Aspects of a New Vehicle in a Virtual Environment: Physical and Virtual Correlation Methods,

FISITA 2004 30th World Automotive Congress, Barcelona, Spain(2004), pp. 23-27.

[3] Haller, M., Holm, R., Volkert, J. and Wagner, R.A. “VR based safety training in a petroleum refinery”. In The 20th Annual Conf. of the European Association of CG, Eurographics, Milano, Italy (1999).

[4] Berta, J. 1999. Integrating VR and CAD. *IEEE Computer Graphics and Applications* 19, 5, 14–19.

[5] Paillot, D., Merienne, F., and Thivent, S. 2003. Cad/cae visualization in virtual environment for automotive industry. In EGVE '03: Proceedings of the workshop on Virtual environments 2003, 315–316.

[6] Baxter, W., Sud, A., Govindaraju, N., Manocha, D. 2002. Gigawalk: Interactive walkthrough of complex environments. In *Eurographics Workshop on Rendering*, 203–214.

[7] Shou, L., Chionh, J., Huang, Z., Ruan, Y., and Tan, K. L. 2001. Walking through a very large virtual environment in real-time. In *VLDB '01: Proceedings of the 27th International Conference on Very Large Data Bases*, 401–410.

[8] PTC. 2007. Division Reality. <http://www.ptc.com/>, Parametric Technology Corporation.

[9] VRContext 2007 <http://www.walkinside.com>

[10] Vahl, M., and Lukas, U. 2003. Integration of virtual reality and cad based on omg’s cad services interface. In *European Concurrent Engineering Conference*, 54–61.

[11] Aveva Group. 2007. VNet - XMP Lant. [http://www.aveva.com/products\\_services\\_aveva\\_plant\\_vnet.php](http://www.aveva.com/products_services_aveva_plant_vnet.php).

[12] OMG. 2007. Computer Aided Design Service, V 1.2. <http://www.omg.org/technology/documents/formal/cad.htm>, Object Management Group, January.

[13] Raposo, A. B., Corseuil, E. T. L., Wagner, G. N., Santos, I. H. F., Gattass, M., 2006. Towards the Use of CAD Models in VR Applications. *ACM International Conference on Virtual-Reality Continuum and its Applications in Industry - VRCAI 2006*, p.67-74. Hong Kong, China.

[14] AUTODESK.2005. 3ds Max. <http://www.autodesk.com>.

[15] Bentley, 1995. Microstation Ref. Guide, Bentley Systems incorporated: Intergraph Standard File Formats.

[16] Bittner et al. 2004. Coherent Hierarchical Culling: Hardware Occlusion Queries Made Useful. *Institute of Computer Graphics and Algorithms, Vienna University of Technology, EUROGRAPHICS 2004*.

[17] Gobbetti E. and Marton F. 2005. "Far voxels: a multiresolution framework for interactive rendering of huge complex 3D models on commodity graphics platforms." *ACM Trans. Graph.* 24, 3, 878-885.

[18] Wagner G. N., Raposo A., Gattass M., 2007, An anti-aliasing technique for voxel-based massive model visualization strategies, *3rd International Symposium on Visual Computing*. LNCS 4841, 288-297.

[19] Toledo, R., Levy, B. Paul J. C. 2007. Iterative Methods for Visualization of Implicit Surfaces on GPU, *3rd International Symposium on Visual Computing*, LNCS 4841, 598-609.

[20] Mourelle, M. M., Gonzalez, E. C. and Jacob, B. P., 1995, “ANFLEX - Computational System for Flexible and Rigid Riser Analysis”, *Proceedings of the 9th International Symposium on Offshore Engineering*, Brazil.